

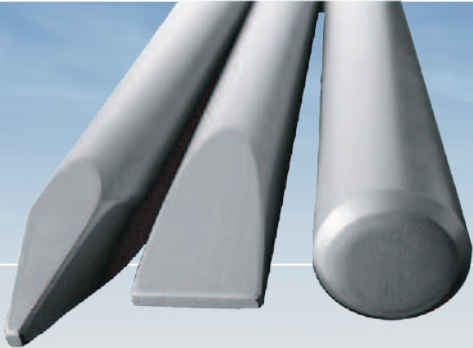

Built to Last Since 1938



AMERICAN PNEUMATIC TOOLS
HANDHELD TOOL STEEL 2014



Support and Service

American Pneumatic Tools (APT) is the leading provider of exceptional tools for the Construction and Industrial markets. APT has been synonymous with quality since 1938.

In their eighth decade, American Pneumatic Tools has represented performance and innovation in the pneumatic tool industry. APT's ever-expanding product line now offers a complete range of pneumatic and hydraulic tools, light compaction, concrete finishing and portable power.

Superior performance, excellent product reliability, competitive pricing, ergonomic designs, and a warranty second to none are what make American Pneumatic Tools an industry leader.

Worldwide Customer Support

Choosing APT is just the beginning. APT distributors offer reliable service and support. Genuine spare parts for your tools are available worldwide, with short delivery times.

Warranty

APT warrants its products to the original purchaser to be free from defective materials and workmanship. The liability of APT is limited to the replacement of any part(s) which are judged to be defective in materials and/or workmanship by APT, provided APT is notified of the suspect part within the warranty period after receipt of the product by the original purchaser. Does not include wear items. This warranty entitles the original purchaser to have the warranted parts and labor rendered at no cost during this warranty period when the product is delivered prepaid to the APT facility in Santa Fe Springs, California. This warranty does not apply to products which APT judges to have been misused, modified or repaired by parties other than APT personnel. This warranty does not apply to tools that have been improperly maintained by the user or when the malfunction or defect can be attributed to the use of parts that are not genuine APT OEM repair parts.

Terms and Conditions

Terms: Net 30 days, FOB Santa Fe Springs, California. Minimum Order: \$50.00 net. All orders totaling less than \$50.00 will be invoiced at \$50.00 net. Freight: APT reserves the right to select all carriers. Damaged or Short Shipments: Always inspect and count all shipments being received and note on the packing list any damage or shortage before the driver leaves your facility. Any claim resulting from shipment must be filed immediately with the carrier and reported to APT within 30 days of delivery.



Authorization To Return Goods

When returning any APT product to the factory for warranty evaluation or for any other reason, the customer must first obtain a RETURN MATERIAL AUTHORIZATION (RMA) number from our customer services department by calling (800) 532-7402, or by faxing (562) 204-1773, with information on the return. The RMA number must be prominently displayed on the packages that are returned to the APT facility and also shown on the packaging list. We reserve the right to refuse any returns without prior authorization. A minimum 20% handling and restocking charge will be applied to all returns unless the situation dictates otherwise and prior authorization is obtained with the RMA number.











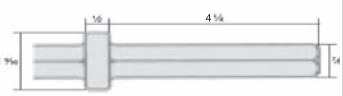

Order Desk Hours

Monday thru Friday
6:00 a.m. to 4:00 p.m. Pacific Time (US & Canada)
8:00 - 16:00 UTC

AMERICAN PNEUMATIC TOOLS

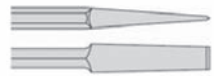

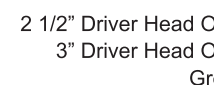

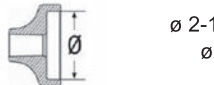







9949 Tabor Place • Santa Fe Springs, CA 90670
Tel (562) 204-1555 • Fax (562) 204-1773
Toll Free Tel (800) 532-7402 • Fax (800) 715-6502
www.apr-tools.com • email: info@apr-tools.com

PAVING BREAKER TOOLS

		7/8" x 3-1/4"		7/8" x 4-1/4"	
					
		Part no.	Length	Part no.	Length
Moil Point 		3083405040 3083405000 3083405010 3083405020 3083405030	10" 14" 18" 24" 36"	3083322800 3083322900	14" 18"
Narrow Chisel 		3083330310 3083330300 3083405110 3083330400 3083405130	10" 14" 18" 24" 36"	3083323000 3083407100	14" 18"
3" Wide Chisel 		3083330500 3083405210 3083405220 3083405230	14" 18" 24" 36"	3083323200 3083407200	14" 18"
Asphalt Cutter 	4-1/2" x 5" 5" x 6"	3083405300	12"	3083323400	12"
Digging Chisel 	3" x 9"	3083330600	14"	3083323300	15"
Clay Spade 	4" x 6-1/2" 5" x 8"	3083330800	17"	3083323500	16"
Frost Wedge 	1-3/8" x 7" 2" x 12"	3083405700	15"	3083323600	15"
Shaft  Small Taper Shank For Tent Stake Cup Driver, Large Taper		3083405800	8"	3083323800 9246020162	8" 9"
ACCESSORIES					
Cup Driver 	2 1/2" Driver Head Only, Large Taper 3" Driver Head Only, Large Taper Ground Rod Driver	9246020159 9245980065		9246020159 9245980065 3083324100	
Tamping Pad 	7" Round, Small Taper 6" Square, Small Taper	3083325210 3083323900		3083325210 3083323900	
Driver Pad 	ø 2-1/2", Small Taper ø 4", Small Taper	3371806012 9245281790		3371806012 9245281790	



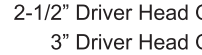

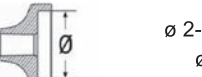







Note: Length is under collar

PAVING BREAKER TOOLS

			
		Part no.	Length
Moil Point 		3083403000 3083403010 3083403020 3083403030	15" 18" 24" 36"
Narrow Chisel 		3083330900 3083403110 3083403120 3083403130	15" 18" 24" 36"
3" Wide Chisel 		3083331000 3083403200 3083403210 3083403220	15" 18" 24" 36"
Asphalt Cutter 	4-1/2" x 5" 5" x 6"	3083403400 3083403300	12" 13"
Digging Chisel 	3-1/4" x 9"	3083331100	15"
Digging Spade / Asphalt Cutter 	4-3/4" x 7-1/2"	3083331200	13"
Clay Spade 	5" x 8"	3083403500	16"
Frost Wedge 	1-3/8" x 7" 2" x 12"	3083331300	15"
Shaft 	Small Taper Shank For Tent Stake Cup Driver	3083403700	11"
ACCESSORIES			
Cup Driver 	2-1/2" Driver Head Only, Large Taper 3" Driver Head Only, Large Taper	9246020159 9245980065	
Tamping Pad 	7" Round, Small Taper 6" Square, Small Taper	3083325210 3083323900	
Driver Pad 	ø 2-1/2", Small Taper ø 4", Small Taper	3371806012 9245281790	

Note: Length is under collar

PAVING BREAKER TOOLS

		1-1/8" x 6"		1-1/4" x 6"		
		Part no.	Length	Part no.	Length	
Moil Point		3083326700 3083401510 3083401520	14" 18" 24"	3083328500 3083400010 3083400020	14" 18" 24"	
Narrow Chisel		3083326800 3083401610 3083401620	14" 18" 24"	3083328600 3083400110 3083400120	14" 18" 24"	
3" Wide Chisel		3083328900 3083401700 3083401710	14" 18" 24"	3083329500 3083400200 3083400210	14" 18" 24"	
Asphalt Cutter		4-1/2" x 5" 5" x 6"	3083401900 3083329000	11" 13"	3083400400 3083329600	12" 13"
Digging Chisel		3" x 9"	3083329100	15"	3083329700	15"
Digging Spade / Asphalt Cutter		5" x 6"	3083329200	13"	3083329800	13"
Clay Spade		5-1/2" x 9"	3083329300	15"	3083329900	15"
Frost Wedge		2" x 12"	3083329400	16"	3083330000	16"
Spiking Tool					9245282671	
Shaft	 Large Taper Shank For Tent Stake Cup Driver	3083326900	9"	3083328700	9"	
ACCESSORIES						
Cup Driver	2-1/2" Driver Head Only, Large Taper 3" Driver Head Only, Large Taper	9246020159 9245980065		9246020159 9245980065		
Tamping Pad	 7" Round, Large Taper 6" Square, Large Taper 8" Square, Large Taper	3083330100 3083330200 3083319700		3083330100 3083330200 3083319700		
Driver Pad	 ø 4-3/4", Large Taper ø 6", Large Taper	3376112079 3376112077		3376112079 3376112077		

Note: Length is under collar







CHIPPING HAMMER TOOLS

		.680 ROUND SHANK OVAL COLLAR		.580 HEX SHANK OVAL COLLAR	
		Part no.	Length	Part no.	Length
Chisel Blank 		3083410500	8-1/4"	3083412500	8-1/4"
		3083410510	11-1/4"	3083412510	11-1/4"
Moil Point 		3083410000	9"	3083412000	9"
		3083410010	12"	3083412010	12"
		3083410020	18"	3083412020	18"
Narrow Chisel 		3083410100	9"	3083412100	9"
		3083410110	12"	3083412110	12"
		3083410120	18"	3083412120	18"
		3083410130	24"		
Scaling Chisel 	1-1/2"	3083410200	9"	3083412200	9"
		3083410210	12"	3083412210	12"
		3083410220	18"	3083412220	18"
	2"	3083410240	12"	3083412240	12"
	2-1/2"	3083410260	9"		
		3083410270	12"	3083412270	12"
	3083410280	18"	3083412280	18"	
Bushing Tool 	2" Square	3083410400	9-1/2"	3083412400	9-1/2"

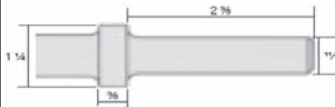
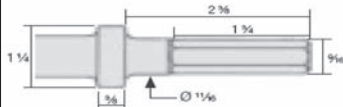
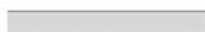



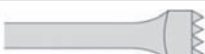



Note: Length is overall length

CHIPPING HAMMER TOOLS

		.680 ROUND SHANK Round Collar 		.580 HEX SHANK Round Collar 	
		Part no.	Length	Part no.	Length
Chisel Blank 		3083410505	8-1/4"	3083412505	8-1/4"
		3083410515	11-1/4"	3083412515	13.09"
Moil Point 		3083411000	9"	3083413000	9"
		3083411010	12"	3083413010	12"
		3083411020	18"		
Narrow Chisel 		3083411100	9"	3083413100	9"
		3083411110	12"	3083413110	12"
		3083411120	18"	3083413120	18"
Scaling Chisel 	1-1/2"	3083411210	12"	3083413210	12"
		3083411220	18"	3083413220	18"
	2"	3083411230	9"		
		3083411240	12"		
		3083411250	18"	3083413250	18"
	2-1/2"	3083411260	9"	3083413260	9"
		3083411270	12"		
		3083411280	18"		
	3"	3083411290	9"	3083413290	9"
	Bushing Tool 	2" Square	3083411400	9-1/2"	3083413400

Note: Length is overall length

RIVET BUSTER TOOLS

		80X Standard		11X Jumbo																									
		Part no.	Length	Part no.	Length																								
Moil Point 		3083414011	9"	3083414000	10"																								
		3083414018	12"	3083414010	12"																								
		3083414022	18"	3083414020	18"																								
Narrow Chisel  <div style="display: flex; justify-content: space-between;"> <div style="width: 30%;"> <p>Concrete work</p> <p>Metal work</p> </div> <div style="width: 65%;"> <table border="1"> <tr> <td>3083414111</td> <td>9"</td> <td>3083414100</td> <td>10"</td> </tr> <tr> <td>3083414118</td> <td>12"</td> <td>3083414110</td> <td>12"</td> </tr> <tr> <td>3083414122</td> <td>18"</td> <td>3083414120</td> <td>18"</td> </tr> <tr> <td></td> <td></td> <td>3083414200</td> <td>10"</td> </tr> <tr> <td></td> <td></td> <td>3083414210</td> <td>12"</td> </tr> <tr> <td></td> <td></td> <td>3083414620</td> <td>18"</td> </tr> </table> </div> </div>	3083414111	9"	3083414100	10"	3083414118	12"	3083414110	12"	3083414122	18"	3083414120	18"			3083414200	10"			3083414210	12"			3083414620	18"					
	3083414111	9"	3083414100	10"																									
	3083414118	12"	3083414110	12"																									
	3083414122	18"	3083414120	18"																									
			3083414200	10"																									
			3083414210	12"																									
		3083414620	18"																										
Side Cut Chisel 		3083414515	9"	3083414500	10"																								
				3083414510	12"																								
				3083414520	18"																								
Ripper Chisel 				3083414400	9-1/2"																								
Driftpin Driver 				3083414300	7-1/2"																								
Back Out Punch 	1/2"	3083414822	9"	3083414700	9-1/2"																								
	5/8"	3083414823	9"	3083414710	9-1/2"																								
	3/4"	3083414851	9"	3083414720	9-1/2"																								
				3083414730	12"																								
	7/8"	3083414871	9"	3083414740	9-1/2"																								
				3083414750	12"																								
4" Long Clearance Back Out Punch 	5/8"			3083414810	10"																								
	3/4"			3083414840	10"																								
	7/8"			3083414870	10"																								
6" Long Clearance Back Out Punch 	5/8"			3083414820	12"																								
	3/4"			3083414850	12"																								
	7/8"			3083414880	12"																								

Note: Length is overall length





ROTARY HAMMER TOOLS



Rd 3/4" x 3-3/4"
For APT109
(also CP0009, AC DKR 36, Sullair MRD-9, & Thor 5LHD)



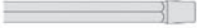



Part no. Length

Moil Point 		3083416000	10"
		3083326100	15"
Narrow Chisel 		3083416100	10"
		3083326200	15"
3" Wide Chisel 		3083416500	10"
Shaft 		3083416200	9"
ACCESSORIES			
Bush Hammer Head 	TC - 9	1-1/2"	3083322600
	TC - 16	1-1/2"	3083322700
	Steel - 9	1-1/4"	3083416300







Plug Hole Drill 	1/2"	3083415000	8"
		3083415010	10-1/2"
	5/8"	3083415100	8"
		3083415110	12"
		3083415120	18"
	3/4"	3083415200	8"
		3083415210	12"
		3083415220	18"
	7/8"	3083415300	8"
		3083415310	12"
		3083415320	18"
	1"	3083415400	8"
		3083415410	12"
		3083415420	18"
1-1/8"	3083415520	18"	
1-1/4"	3083415600	8"	
	3083415610	12"	
	3083415620	18"	

Note: Length is overall length

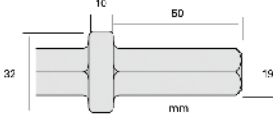
MISCELLANEOUS WORKING TOOLS

			
		Part no.	Length
Tie Tamper 	7/8" x 4-1/4"	3083323700	15"
		9245282330	18"
		9245282240	22"
	1-1/4" x 6"	3083331400	18"
Feather & Wedge Set 		9245281381	1-3/16"
		9245281351	1-3/8"

ADDITIONAL WORKING TOOLS

		Hexagon Shank 3/4 x 2" 	
		Part no.	Length
Moil Point 		3083322000	12"
		3083322100	20"
Narrow Chisel 		3083322200	12"
		3083322300	20"
2 3/8" Wide Chisel 		3083322400	10"
Shaft 		3083322500	5-1/2"
ACCESSORIES			
Bush Hammer Head 	TC	1-1/2"	3083322600
	TC	1-1/2"	3083322700
	Steel	1-1/4"	3083416300

Note: Length is overall length, Flat to Flat

CARBIDE TIPPED INTEGRAL DRILL STEEL



Drill Size - In.	Drill Depth	Length Under Collar	Hexagon Shank 7/8 x 3-1/4"	Hexagon Shank 7/8 x 4-1/4"
			Part No.	Part No.
5/8"	6"	9"	3083420000	3083421000
5/8"	9"	12"	3083420010	3083421010
5/8"	14"	18"	3083420020	3083421020
3/4"	6"	9"	3083420100	3083421100
3/4"	9"	12"	3083420110	3083421110
3/4"	14"	18"	3083420120	3083421120
3/4"	20"	24"	3083420130	3083421130
3/4"	26"	30"	3083420140	3083421140
7/8"	6"	9"	3083420200	3083421200
7/8"	9"	12"	3083420210	3083421210
7/8"	14"	18"	3083420220	3083421220
7/8"	20"	24"	3083420230	3083421230
7/8"	26"	30"	3083420240	3083421240
1"	6"	9"	3083420300	3083421300
1"	9"	12"	3083420310	3083421310
1"	14"	18"	3083420320	3083421320
1"	20"	24"	3083420330	3083421330
1"	26"	30"	3083420340	3083421340
1-1/8"	9"	12"	3083420400	3083421400
1-1/8"	14"	18"	3083420410	3083421410
1-1/8"	20"	24"	3083420420	3083421420
1-1/8"	26"	30"	3083420430	3083421430
1-1/4"	9"	12"	3083420500	3083421500
1-1/4"	14"	18"	3083420510	3083421510
1-1/4"	20"	24"	3083420520	3083421520
1-1/4"	26"	30"	3083420530	3083421530
1-3/8"	9"	12"	3083420600	3083421600
1-3/8"	14"	18"	3083420610	3083421610
1-3/8"	20"	24"	3083420620	3083421620
1-3/8"	26"	30"	3083420630	3083421630
1-1/2"	9"	12"	3083420700	3083421700
1-1/2"	14"	18"	3083420710	3083421710
1-1/2"	20"	24"	3083420720	3083421720
1-1/2"	26"	30"	3083420730	3083421730



H THREAD RODS



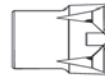

Length Under Collar	Hexagon Shank 7/8 x 3-1/4"	Hexagon Shank 7/8 x 4-1/4"	Hexagon Shank 1 x 4-1/4"
	Part No.	Part No.	Part No.
12"	3083422100	3083422000	3083422200
18"	3083422110	3083422010	3083422210
24"	3083422120	3083422020	3083422220
30"	3083422130	3083422030	3083422230
36"	3083422140	3083422040	3083422240
48"	3083422150	3083422050	3083422250
60"	3083422160	3083422060	3083422260
72"	3083422170	3083422070	3083422270
96"	3083422180	3083422080	3083422280

H THREAD HEAVY DUTY CARBIDE BITS



Diameter	Part No.
1-3/8"	3083422300
1-1/2"	3083422310
1-5/8"	3083422320
1-3/4"	3083422330
1-7/8"	3083422340
2"	3083422350
2-1/4"	3083422360
2-1/2"	3083422370
3"	3083422380

GAS POWERED TOOL ACCESSORIES

		Part no.	Shank size
U-Channel Driver - Cup Only 		9246020583	Cup Only
U-Channel Driver - Pipe Driver 	Small Taper Small Taper Small Taper Small Taper	9246020579 9246020580 9246020581 9246020582	7/8" x 4-1/4" 1" x 4-1/4" 1-1/8" x 6" 1-1/4" x 6"
Telespar - Square Post Driver Head 	1-1/2", Large Taper 1-3/4", Large Taper 2", Large Taper 2-1/2", Large Taper	9245982010 9245982020 9245982030 9245982040	Head Only, for 1-3/4" Base Head Only, for 2" Base Head Only, for 2-1/4" Base Head Only, for 2-1/2" Base
Telespar - Square Post Driver Shank Only 	Large Taper Large Taper Large Taper	9246020162 9246020160 9246020161	7/8" x 4-1/4" 1-1/8" x 6" 1-1/4" x 6"
Tent Stake Driver - One Piece 		9753217399	7/8" x 4-1/4" (2-3/8" ID, 9" UC)

APT steel shanks are produced to ISO 1180 dimensional tolerances ensuring the correct fit for the tool bushing and correct piston striking position. Some machines are very sensitive to incorrect shank dimensions. Using the wrong or substandard working tool steel may cause irreversible damage to your machine.



Freight Policy

American Pneumatic Tools is pleased to announce our new freight policy relating to small packages. Small package shipments are defined as those weighing 150 pounds or less. If a shipment is over 150 pounds and needs to ship by LTL carrier, actual freight charges will apply. Policy details, rates per zone and map (illustrating the zones by region) follow below.

Benefits:

- **Distributors will know their expected freight charges quicker, same day in most cases.**
- **Consistency of division policies for multi-line dealers**

We are available at 800-532-7402 or info@apt-tools.com to answer any questions regarding this policy.

This policy applies to Working Tool Steel:

1. Freight for all Fed Ex and UPS small package shipments will be automatically charged up front on all sales orders.
2. Freight will be based on item weight and level of service combination.
3. Requirements for free freight: Order type must be Stock Order (SR), SR order value has to be a minimum of \$1,000, and the SR order must be delivered to a Distributor ship to address.
4. Freight for the entire order will be charged on the first invoice/shipment of a sales order.



Built to Last Since 1938

APT

American Pneumatic Tools Products

Power

Compressors

Generators

Handheld Pneumatic

Paving Breakers

Rock Drills

Clay/Trench Diggers

Backfill Tampers

Demolition Tools

Chipping Hammers

Needle Scalers

Light Compaction

Walk-behind Roller

Reversible Plate Compactors

Forward Plate Compactors

Rammer Tampers

Concrete Finishing

Pneumatic Vibrators

Power Trowels

Screeds

Rig Tools

Hydraulic Breakers

AMERICAN PNEUMATIC TOOLS

9949 Tabor Place • Santa Fe Springs, CA 90670

Tel (562) 204-1555 • Fax (562) 204-1773

Toll Free Tel (800) 532-7402 • Fax (800) 715-6502

www.apr-tools.com • email: info@apr-tools.com