

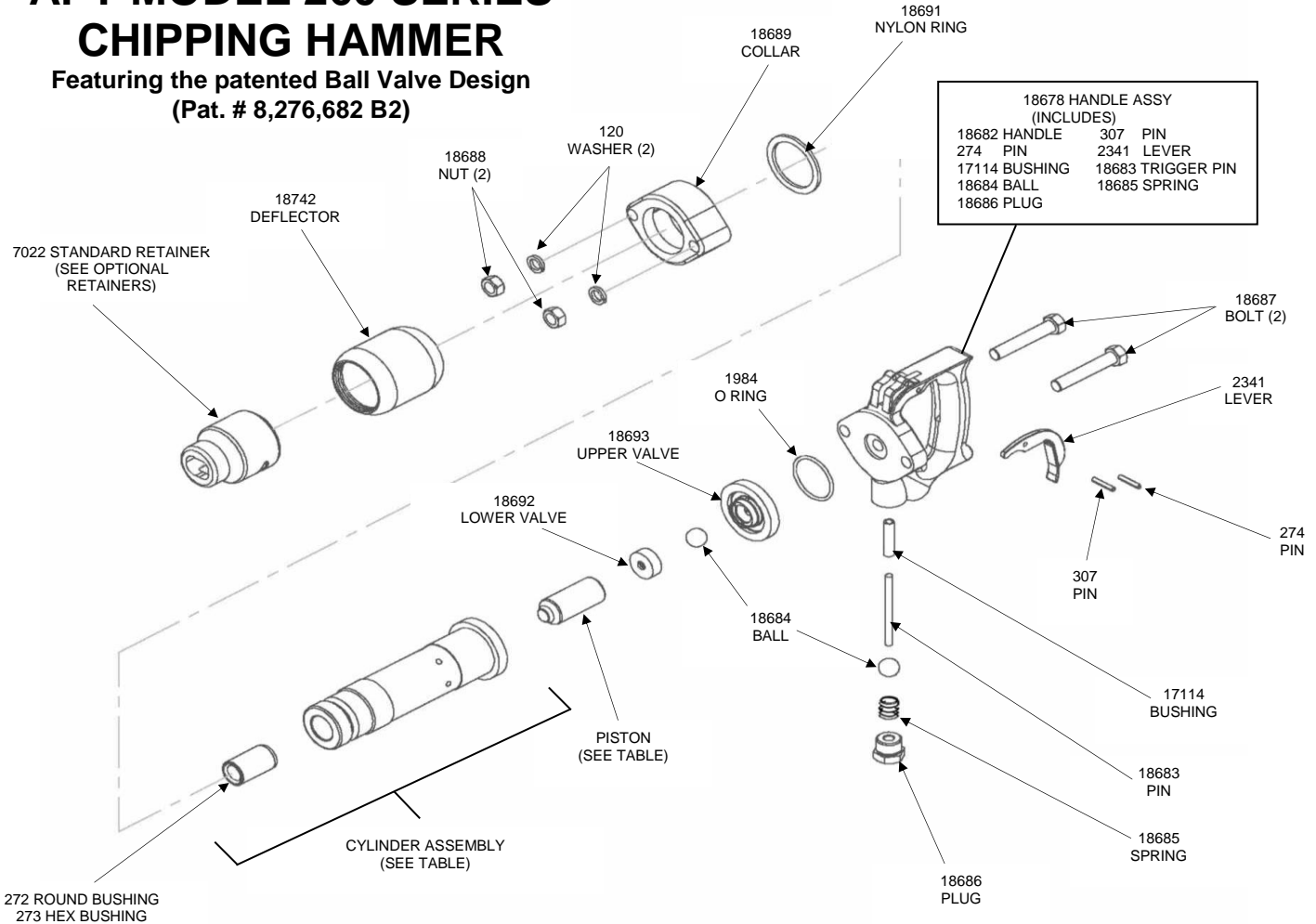

American Pneumatic Tools

APT MODEL 260 SERIES CHIPPING HAMMER

Featuring the patented Ball Valve Design
(Pat. # 8,276,682 B2)



2 BOLT CHIPPING HAMMER		
MODEL	CYLINDER ASSEMBLY	PISTON
M263, 3" STROKE, ROUND BUSHING	18673	1534
M263, 3" STROKE, HEX BUSHING	18676	1534
M264, 4" STROKE, ROUND BUSHING	18674	703
M264, 4" STROKE, HEX BUSHING	18677	703

For assistance in any sales, technical, maintenance or repair questions, please call APT @
 Phone: (800) 532-7402 or (714) 285-2828 • Fax: (800) 715-6502 or (714) 285-2829
 1000 S. Grand Ave, Santa Ana, CA 92705

Website: www.apr-tools.com • e-mail: info@apr-tools.com

TDS-1059 Rev B

© 2017 AMERICAN PNEUMATIC TOOLS a business unit within: Construction Equipment North America LLC.



American Pneumatic Tools

APT MODEL 650 SERIES CHIPPING HAMMER

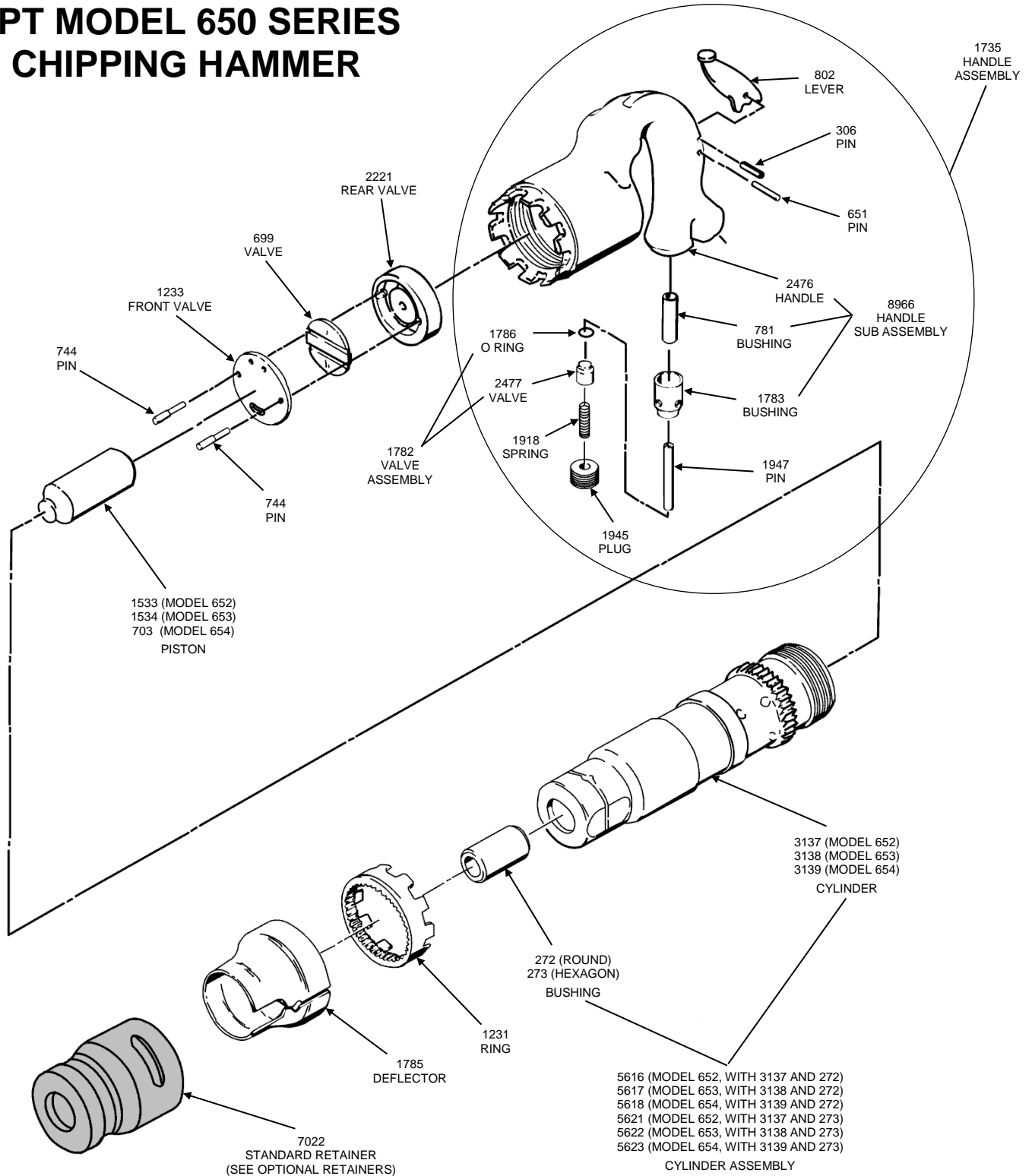

For assistance in any sales, technical, maintenance or repair questions, please call APT @
 Phone: (800) 532-7402 or (714) 285-2828 • Fax: (800) 715-6502 or (714) 285-2829
 1000 S. Grand Ave, Santa Ana, CA 92705

Website: www.apr-tools.com • e-mail: info@apr-tools.com

TDS-1061 Rev B

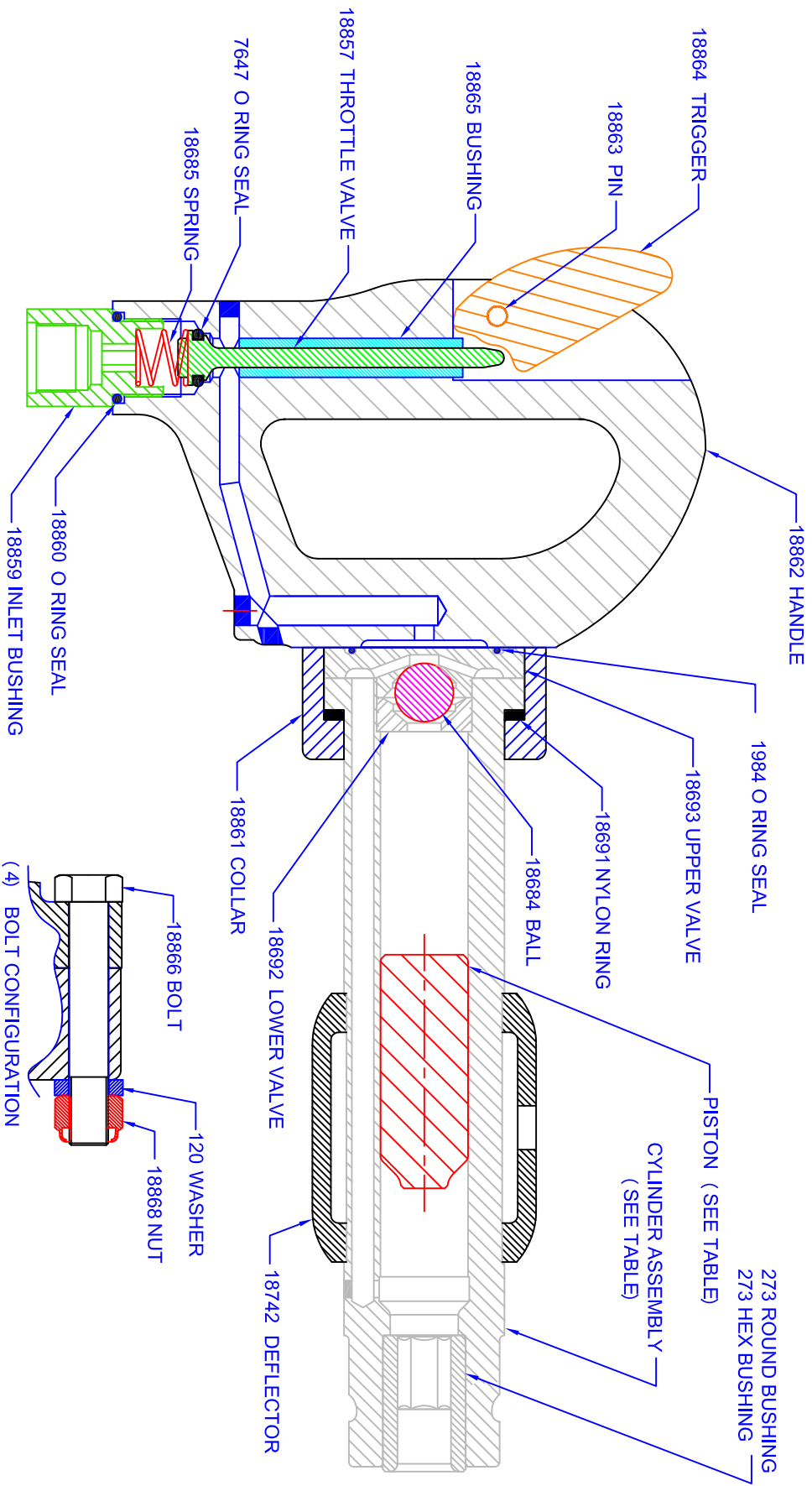

MODEL	CYLINDER ASSEMBLY #	PISTON #
3" STROKE - .680" ROUND BUSHING	18673	1534
3" STROKE - .580" HEX BUSHING	18676	1534
4" STROKE - .680" ROUND BUSHING	18674	703
4" STROKE - .580" HEX BUSHING	18677	703

ASSEMBLY PART NUMBERS (ALL MODELS)

- HANDLE ASSEMBLY-COMLETE 18854 (18865, 18863, 18864, 18855, 18856 & 18858)
- HANDLE SUB ASSEMBLY 18855 (18862 & 18865)
- THROTTLE VALVE ASSEMBLY 18856 (18857 & 7647)
- INLET BUSHING ASSEMBLY 18858 (18859 & 18860)

**M43R, M43H, M44R, M44H
4 BOLT CHIPPING HAMMERS**

- 3" STROKE - .680" ROUND BUSHING 18850
- 3" STROKE - .580" HEX BUSHING 18851
- 4" STROKE - .680" ROUND BUSHING 18852
- 4" STROKE - .580" HEX BUSHING 18853

REQUIRED RETAINER SYSTEM - 3 OPTIONS
 9431 STANDARD RETAINER (7022) WITH 1941 SPRING
 5550 QUICK CHANGE RETAINER WITH 1941 SPRING
 18290 QUICK CHANGE, BOLT ON RETAINER

AMERICAN PNEUMATIC TOOLS

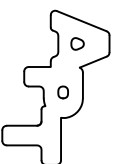

(A BUSINESS UNIT WITHIN : CONSTRUCTION EQUIPMENT NORTH AMERICA LLC)
 1000 SOUTH GRAND AVENUE, SANTA ANA, CALIFORNIA 92705
 www.apptools.com : Ph. (714) 285 2828 : Fax (714) 285 2829